

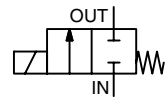

SOLENOID VALVES

direct operated
for low pressure gas, according to EN 161
3/8 to 1

NC



2/2
Series
040

FEATURES

- For gas pilot and gas burner control on industrial atmospheric and forced draught burners, also used in kilns and furnaces in process industries
- All valves have been type tested to EN 161 and satisfy the European gas appliance directive (2009/142/EC)
Certificate of conformity BSI: No. CE 592900)
- All valves are for class A group 2 service and cover gas family 1, 2 and 3
- All valves are suitable to withstand 150 mbar back pressure
- Aluminium bodied, low pressure valves designed to provide maximum flow
- Direct lift valves with resilient soft seating for tight shut-off

GENERAL

Differential pressure See «SPECIFICATIONS» [1 bar = 100 kPa]
Response time 1 s max.

fluids (*)	temperature range (TS)	seal materials (*)
combustible gas	0°C to +60°C	NBR (nitrile)



MATERIALS IN CONTACT WITH FLUID

(*) Ensure that the compatibility of the fluids in contact with the materials is verified

Body	Aluminium
Core tube	Stainless steel
Core and plugnut	Stainless steel
Springs	Stainless steel
Seat	Aluminium
Seal	NBR
Disc	NBR
Riderring	PTFE
Core guide	POM
Shading coil	Copper

ELECTRICAL CHARACTERISTICS

Coil insulation class F
Connector Spade plug (cable Ø 6-10 mm)
Connector specification ISO 4400 / EN 175301-803, form A
Electrical safety IEC 335
Electrical enclosure protection Moulded IP65 (EN 60529)
Standard voltages AC (~) : 24V - 48V - 115V - 230V / 50 Hz
(Other voltages on request)

prefix option	power ratings				operator ambient temperature range (TS) (C°)	replacement coil		type ⁽¹⁾
	inrush ~	holding ~		hot/cold =		~	=	
	(VA)	(VA)	(W)	(W)		230 V/50 Hz		
EGSC	85	35	14	-	0 to +60	400902-117	-	01
	127	46	20	-	0 to +60	400903-117	-	02

⁽¹⁾ Refer to the dimensional drawings on the following page.

SPECIFICATIONS

pipe size	orifice size	flow ⁽²⁾		operating pressure differential (bar)				power coil (W)		catalogue number
				min.	max. (PS)					
					gas (*)					
Rp	(mm)	(m³/h)	(l/min)		~	=		~	=	~
NC - Normally closed										
3/8	19	4,9	81,7	0	0,086	-		14	-	EGSCE040B001
1/2	19	7	116,7	0	0,086	-		14	-	EGSCE040B002
3/4	19	10,3	172	0	0,086	-		14	-	EGSCE040B003
1	23,8	14,84	247	0	0,086	-		20	-	EGSCE040A024 ⁽³⁾

⁽²⁾ For 2,5 mbar pressure drop air 1,0 s.g. at 1,013 mbar and 15°C.

⁽³⁾ Valves to be mounted vertical and upright.

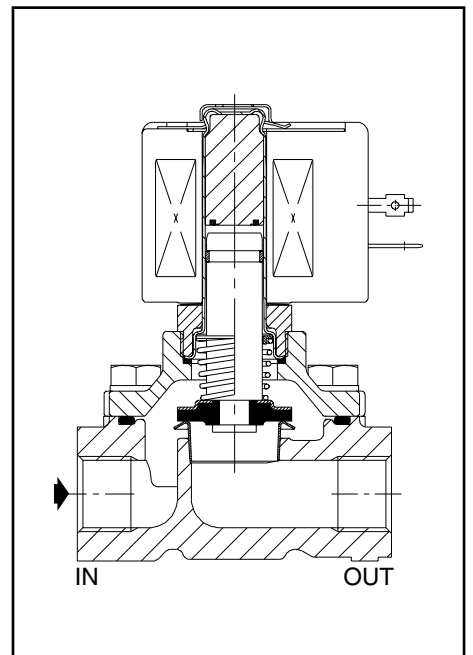

ТОРГОВО-ИНЖЕНЕРНЫЙ ЦЕНТР

+7(495)788-54-55 www.airar.ru info@airar.ru

V902-17-1

OPTIONS

- Mounting brackets, suffix MB (EGSCE040B001/002/B003 only)
- Optional features to EGSCE040B001/002/B003:
 - Strainer, used suffix D01
 - 1/8" plugged pressure tappings in the inlet and outlet ports, use suffix D02
 - Strainer and 1/8 plugged pressure tappings in the inlet and outlet ports, used suffix D03
 - Pressure test nipples for hose connection in the inlet and outlet ports Ø 8 mm, use suffix D04
 - Strainer and Pressure test nipples for hose connection in the inlet and outlet ports Ø 8 mm, use suffix D05
- Plug with visual indication and peak voltage suppression or with cable length of 2 m (see Solenoids, Coils & Accessories section)

INSTALLATION

- The B001/B002/B003 solenoid valves can be mounted in any position without affecting operation. The A024 solenoid valves must be mounted vertical and upright
- Standard integrated strainers at the inlet port for valve type A024. Strainers are optional for types B001, B002 and B003
- Pipe connection identifier is E = Rp (ISO 7/1)
- Installation/maintenance instructions are included with each valve

SPARE PARTS KIT

catalogue number	spare parts kit no.	
	~	=
EGSCE040B001/B002/B003	K312984	-
EGSCE040A024	K320011	-

- Not available.

ORDERING EXAMPLES:

EGSC	E	040	B	001	230V / 50 Hz
EGSC	E	040	A	024	115V / 50 Hz

prefix ————
 pipe thread ————
 basic number ————
 voltage ————
 suffix ————

ORDERING EXAMPLES KITS:

	K312984
basic number	—————

DIMENSIONS (mm), WEIGHT (kg)

TYPE 01
 Prefix "EGSC" Solenoid
 Epoxy moulded
 IEC 335 / ISO 4400
 IP65

EGSCE040B001/B002/B003

TYPE 02
 Prefix "EGSC" Solenoid
 Epoxy moulded
 IEC 335 / ISO 4400
 IP65

EGSCE040A024

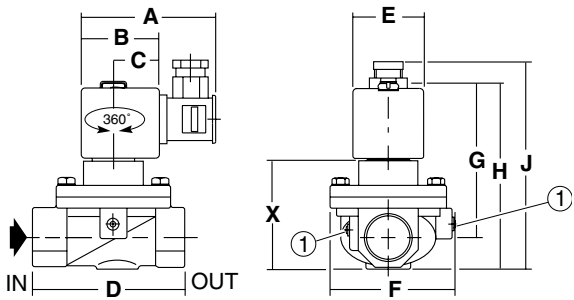
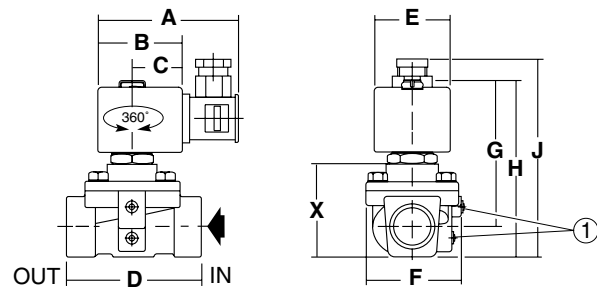

type	prefix option	catalogue number	A	B	C	D	E	F	G	H	J	X	weight ⁽¹⁾
01	EGSC	EGSCE040B001/B002	77	50	30	70	45	59	83	98	114	47	0,9
		EGSCE040B003	77	50	30	83	45	59	88	109	125	58	0,7
02	EGSC	EGSCE040A024	86	56	33	108	50	89	112	130	135	55	1,4

⁽¹⁾ Inlet and outlet ports pressure tapping Rp 1/8 (standard for type A024 and optional for types B001, B002 and B003)

⁽¹⁾ include coil and connector or metal housing.