



MINI-VALVES

pressure operated
stainless steel body

food connections to DIN 11851 - DN 10 to 20

NC

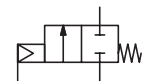

NO

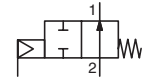

2/2
Series
Y290

FEATURES

- High flow due to angled seat design
- Anti-waterhammer design (fluid entry under the disc)
- External threads to DIN 11851
- Vacuum operation up to 10^{-2} mbar
- Piston-type operators 32 mm dia. rotatable through 360°
- Valve body pickled in nitric/fluoric acid bath (NET-INOX passivation treatment)
- High performance, maintenance-free stuffing box
- The valves satisfy Pressure Equipment Directive 97/23/EC, article 3.3
- The valves in conformity with IEC 61508 Standard (2010 route 2_H version) certified with integrity levels: SIL 2 for HFT = 0

GENERAL

Differential pressure	See «SPECIFICATIONS» [1 bar = 100 kPa]
Maximum allowable pressure	16 bar
Ambient temperature range	-10°C to +60°C
Maximum viscosity	600 cSt (mm ² /s)
Pilot fluid	Filtered air or water ⁽¹⁾
Max. pilot pressure	10 bar
Min. pilot pressure	See below
Pilot fluid temperature	-10°C to +60°C
Response time	See page V402-7

fluids (*)	temperature range	disc seal (*)
air and gas groups 1 & 2 water, oil, liquids groups 1 & 2 and steam	- 10°C to + 184°C	PTFE

MATERIALS IN CONTACT WITH FLUID

(*) Ensure that the compatibility of the fluids in contact with the materials is verified

Valve body	All AISI 316L
Stuffing box housing	AISI 316L ⁽²⁾
Stem	AISI 316L
Disc	AISI 316L
Stuffing box packing	PTFE chevrons
Wiper seal	FPM
Disc seal	PTFE
Valve body seal	PTFE

OTHER MATERIALS

Operator	Glass fibre filled PA
Optical position indicator	Optional on NC valves

⁽¹⁾ For dia. 32 operators: At service fluid temperatures inside the valve body above 100°C, it is prohibited to pilot the valve with water.
⁽²⁾ NET-INOX passivation treatment included.

SPECIFICATIONS

piping		flow coefficient Kv		pilot pressure (bar)		operating pressure differential (bar)				operator diameter (mm)	catalogue number
pipe size	DN	(m ³ /h)	(l/min)	min.	max.	min..	max.				
DIN 11851							air, inert gas, aggressive fluids (*)	water, oil, liquids, aggressive liquids (*)	steam (*) (≤184°C)		
NC - Normally closed, entry under the disc ⁽³⁾											
RD 28 x 1/8	10	2,8	47	4	10	0	16	16	10	32	Y290A791
RD 34 x 1/8	15	4,1	68	4	10	0	12	12	10	32	Y290A792
RD 44 x 1/6	20	6,5	108	4	10	0	6	6	6	32	Y290A793
NO - Normally open, entry under the disc											
RD 28 x 1/8	10	2,8	47	IX (*)	10	0	16	16	10	32	Y290A794
RD 34 x 1/8	15	4,1	68	IX (*)	10	0	16	16	10	32	Y290A795
RD 44 x 1/6	20	6,5	108	IX (*)	10	0	16	16	10	32	Y290A796
NC - Normally closed, entry above the disc (version recommended for rapid-cycling steam applications)											
RD 28 x 1/8	10	2,8	47	X (*)	10	0	10	-	10	32	Y290A797
RD 34 x 1/8	15	4,1	68	X (*)	10	0	10	-	10	32	Y290A798
RD 44 x 1/6	20	6,5	108	X (*)	10	0	10	-	10	32	Y290A799

(*) Minimum pilot pressure varies with differential pressure, see page V402-7.

⁽³⁾ Calculation of the minimum pilot pressure at max. ΔP with allowable backpressure, contact us (backpressure not recommended with liquids as waterhammer may occur).

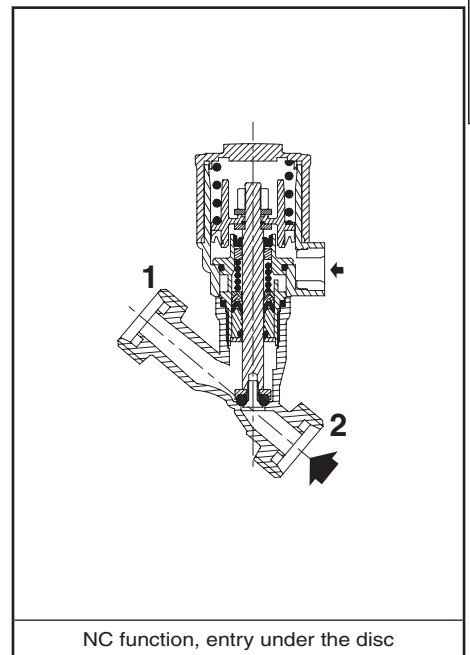

NC function, entry under the disc



ТОРГОВО-ИНЖЕНЕРНЫЙ ЦЕНТР

+7(495)788-54-55 www.airar.ru info@airar.ru

OPTIONS AND ACCESSORIES (see page V435/V436)

- Optical position indicator, NC function
- Oxygen service, pressure limited to 15 bar, temperature limited to + 60°C
- Vacuum applications up to 1,33 10⁻³ mbar
- ATEX 94/9/EC versions for potentially explosive atmospheres
- Other pipe connections are available on request

INSTALLATION

- The valves can be mounted in any position without affecting operation
- Compatible with ASTM 1, 2 and 3 oils
- Check temperature range of valve body and solenoid pilot valves for suitability. For probability of failure, contact us
- Pipe connections have standard threads to DIN 11851
- Installation/maintenance instructions are included with each valve

SPARE PARTS KITS

DN	spare parts kit no.
10	C140100
15	C140101
20	C140102

ORDERING EXAMPLES:

	Y	290	A	791	
	Y	290	A	792	VI
	Y	290	A	799	

pipe thread _____
 basic number _____
 suffix _____

ORDERING EXAMPLES KITS:

	C140102
--	---------

basic number _____

DIMENSIONS (mm), WEIGHT (kg)

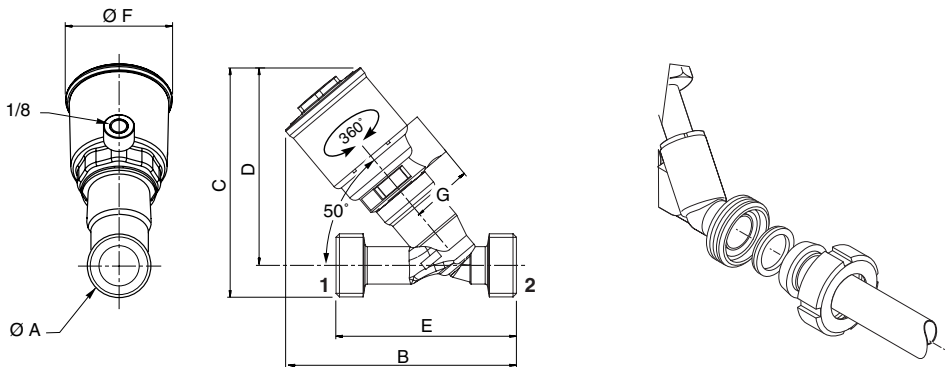
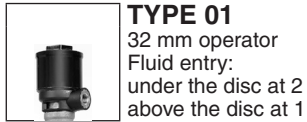

type	operator diameter	ØA	B	C	D	E	ØF	G	weight ⁽¹⁾
01	32 mm	RD 28 x 1/8	102,5	101,7	87,7	80	43,5	27	0,41
		RD 34 x 1/8	104,9	105,8	88,8	90	43,5	27	0,46
		RD 44 x 1/6	109,6	110,4	88,4	110	43,5	27	0,68

⁽¹⁾ Weight of valve without pilot.

Solenoid pilot valves: see V439 (32 mm operator)

