

FEATURES

- The monostable spool valves have TÜV certified IEC 61508 Functional Safety data and can be used up to SIL 4
- All the exhaust ports of this spool valve are connectable, providing better environmental protection, particularly recommended for sensitive areas such as clean rooms, and applications in the pharmaceutical and food processing sectors
- The valve offers environmental protection against the ingress of liquids, dusts or any other foreign matter (environmentally-protected construction)
- Can be externally piloted (external air pilot supply) to convert valve to zero minimum operation by flipping a gasket
- The solenoid valves satisfy all relevant EC Directives

GENERAL

Differential pressure 2 - 10 bar [1 bar =100 kPa]
Flow (Qv at 6 bar) 860 l/min (ANR)

fluids (*)	temperature range (TS)	seal materials (*)
air, inert gas, filtered	- 40°C to + 60°C	VMQ (silicone) + PUR (polyurethane)

MATERIALS IN CONTACT WITH FLUID

(*) Ensure that the compatibility of the fluids in contact with the materials is verified

Body, end covers	Brass
Spool valve internal parts	Brass, stainless steel, POM
Core tube	Stainless steel
Core and plugnut	Stainless steel
Core spring	Stainless steel
Seals & discs	NBR
Top disc	PA
Disc holder	POM
Cartridge (low power)	Welded, packless AISI 430
Seat	Brass
Seat insert	POM
Shading coil	Copper
Rider ring (low power)	PTFE

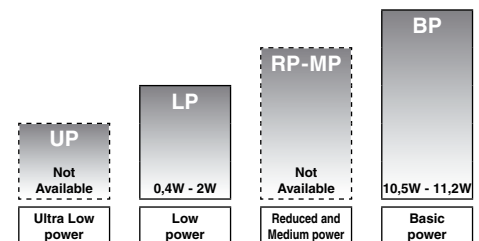
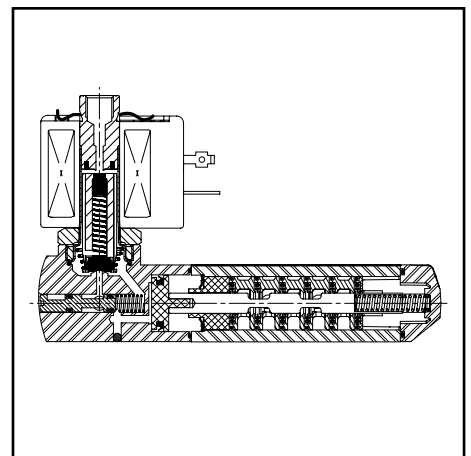

POWER LEVELS - cold electrical holding values (watt)

SPECIFICATIONS

pipe size	orifice size	flow coefficient kv		operating pressure differential (bar)			power level	prefix optional solenoids											basic catalogue number
								max. (PS)		NEMA 7 & 9	ATEX / IECEx				IP65				
				min. ⁽²⁾	air (*)	EF		LPKF	NF		EM	PV	LI	IS		ZN	SC		
(*)	(mm)	(m³/h)	(l/min)	~	=	~/=													
Solenoid air pilot operated - spring return (monostable)																			
1/4	6	0,75	12,5	0 / 2	10	10	BP	-	-	●	-	●	●	-	-	●	●	❖551A419 ⁽¹⁾	
1/4	6	0,75	12,5	0 / 2	10	10	BP	●	-	-	-	-	-	-	-	-	-	❖551G419 ⁽¹⁾	
1/4	6	0,75	12,5	0 / 2	10	10	LP	-	○	●	-	●	○	○	○	○	●	❖551A319 ⁽¹⁾	
1/4	6	0,75	12,5	0 / 2	10	10	LP	○	-	-	-	-	-	-	-	-	-	❖551G319 ⁽¹⁾	
Solenoid air pilot operated and return (bistable)																			
1/4	6	0,75	12,5	0 / 2	10	10	BP	-	-	●	-	●	●	-	-	●	●	❖551A420	
1/4	6	0,75	12,5	0 / 2	10	10	BP	●	-	-	-	-	-	-	-	-	-	❖551G420	
1/4	6	0,75	12,5	0 / 2	10	10	LP	-	○	●	-	●	○	○	○	○	●	❖551A320	
1/4	6	0,75	12,5	0 / 2	10	10	LP	○	-	-	-	-	-	-	-	-	-	❖551G320	

❖ Select 8 for NPT ANSI 1.20.3 or select G for ISO G (228/1) ● Available feature ○ Available feature in DC only.

(1) Certified IEC 61508 Functional Safety data, use suffix "SL" (Not to use with LPKF suffix).

(2) Zero minimum is only achieved if external pressure is applied.

PREFIX TABLE

prefix							description	power level			
1	2	3	4	5	6	7		LP	RP	MP	BP
S	C			D	U		Dustproof (EN 50281-1-1)*	-	-	-	●
E	F						Explosionproof - NEMA 7, 9 - Zinc plated steel conduit	○	-	-	●
E	V						Explosionproof - NEMA 7, 9 - 316 SS conduit	○	-	-	●
E	M						Waterproof IP67 - Metal enclosure (EN/IEC 60079-7+18, 61241-1)*	●	-	-	●
		E	T				Threaded conduit/hole (M20 x 1,5)	●	-	-	●
I	S			S	C		Intrinsically safe with SC coil (EN/IEC 60079-11+26, 61241-11)*	○	-	-	-
L	P	K	F				Flameproof - Aluminium (EN/IEC 60079-1, 61241-1)*	●	-	-	-
N	F						Flameproof - Aluminium (EN/IEC 60079-1, 61241-1)*	●	-	-	●
P	V						Encapsulated epoxy moulded (EN/IEC 60079-18, 61241-18)*	○	-	-	●
S	C						Solenoid with spade plug connector (EN/IEC 60730)	●	-	-	●
W	P						Waterproof IP67 - Metal enclosure	●	-	-	●
W	P			D	U		Waterproof IP67 - Metal enclosure, Dustproof (EN 50281-1-1)*	-	-	-	●
L	I						I.S. with Aluminium IP67 enclosure (EN/IEC 60079-11 / 61241-1)*	○	-	-	-
W	P			I	S		I.S. with Metal IP67 enclosure (EN/IEC 60079-11+26, 61241-11)*	○	-	-	-
W	S						Waterproof IP67 - 316 SS enclosure	●	-	-	●
W	S			D	U		Waterproof IP67 - 316 SS enclosure, Dustproof (EN 50281-1-1)*	-	-	-	●
W	S	L	P	K	F		Flameproof - 316 SS (EN/IEC 60079-1, 61241-1)*	●	-	-	-
W	S	E	M				Waterproof IP67 - 316 SS enclosure (EN/IEC 60079-7+18, 61241-1)*	●	-	-	●
W	S			L	I		I.S. with 316L SS IP67 enclosure (EN/IEC 60079-11, 61241-1)*	○	-	-	-
W	S			I	S		I.S. with 316 SS IP67 enclosure (EN/IEC 60079-11+26, 61241-11)*	○	-	-	-
W	S	N	F				Flameproof - 316 SS (EN/IEC 60079-1, 61241-1)*	●	-	-	●
Z	N						Moulded enclosure (EN 50021, 50281-1-1)*	○	-	-	●
		T					Threaded conduit (1/2" NPT)	●	-	-	●
				H	T		Class H - High temperature, +80°C ambient temp.	-	-	-	●
						X	Other special constructions	●	-	-	●

SUFFIX TABLE

suffix							description	power level			
1	2	3	4	5	6	7		LP	RP	MP	BP
			M	O			Push type manual operator	○/●	-	-	●
S	L						Certified IEC 61508 Functional Safety data (2)	○/●	-	-	●

OPTIONS & ACCESSORIES

series	pipe size	exhaust protector (stainless steel)
551	G 1/8	34600418 (1)
	NPT 1/8	34600482 (1)
	G 1/4	34600419 (1)
	NPT 1/4	34600483 (1)
	M5	34600484 (1)

- Available feature
- Available feature in DC only
- Not available
- * ATEX solenoids are also approved according to EN 13463-1 (non electrical valves)
- (1) Provided with "SL" suffix
- (2) Not to use with MO suffix

ORDERING EXAMPLES:

SC	G	551	A	419		230V / 50 Hz
SC	G	551	A	419	SL	230V / 50 Hz
SC	G	551	A	420	MO	230V / 50 Hz
SCHT	8	551	A	420	MO	230V / 50 Hz
ISSC	G	551	A	420	MO	24V / DC
WSPKPF	G	551	A	319	MO	24V / DC
LPKF	G	551	A	319	MO	24V / DC
LI	G	551	A	319		24V / CDC
WSLI	G	551	A	320	MO	24V / DC
WPIS	G	551	A	319		24V / DC
EM	8	551	A	419	MO	230V / 50 Hz
EF	G	551	G	419	MO	240V / 60 Hz

prefix (3) ———
 pipe thread ———
 basic number (3) ——— voltage
 suffix ———

(3) Prefixes EF and EV should always be used with the letter G in the basic number.

PRODUCT SELECTION GUIDE

STEP 1

Select the fluid temperature range and seal material from the general table on page 1. Select basic catalogue number, including pipe thread identification letter. Refer to the specifications table above.

Example : G551A419

STEP 2

Select prefix (combination). Select the appropriate operator from the specifications table on page 1 and the prefix table on page 2. Select for this operator in the electrical characteristics table on page 3: the power level (LP, BP), the type of electrical enclosure protection and the desired temperature class.

Warning: The ambient temperature range of your application may not exceed the temperature range of your operator.

Example : EM

STEP 3

Select suffix (combination) if required.

Example : MO

STEP 4

Select voltage. Refer to standard voltages on page 3.

Example : 230V / 50Hz

STEP 5

Final catalogue / ordering number.

Example :

EM G551A419MO 230 V / 50 Hz

EXPLANATION OF TEMPERATURE RANGES OF SOLENOID VALVES

- Valve temperature range The valve temperature range (TS) is determined by the selected seal material, the temperature range for proper operation of the valve and sometimes by the fluid (e.g. steam)
- Operator ambient temperature range The operator ambient temperature range is determined by the selected power level and the safety code
- Total temperature range The temperature range of the complete solenoid valve is determined by the limitations of both temperature ranges above

ELECTRICAL CHARACTERISTICS

- Coil insulation class F
- Electrical safety IEC 335
- Standard voltages DC (=) 24V - 48V
AC (~) 24V - 48V - 115V - 230V⁽⁶⁾/50Hz; other voltages and 60Hz are available on request

prefix option	power ratings				operator ambient temperature range (TS) (C°) ⁽¹⁾	safety code	electrical enclosure protection (EN 60529)	replacement coil / kit		type ⁽²⁾
	inrush	holding	hot/cold					~	=	
	(VA)	(VA)	(W)	(W)				230 V/50 Hz	24V/DC	
Basic power (BP)										
SC	55	23	10,5	9/11,2	-40 to +75	EN 60730	IP65 moulded	400425-117	400425-142	01
SCDU	55	23	10,5	9/11,2	-40 to +75	II3D IP65 T 200°C(-)/135°C(=)	IP65 moulded	- ⁽⁴⁾	- ⁽⁴⁾	01
WP/WS	55	23	10,5	9/11,2	-40 to +75	EN 60730	IP67 steel/SS	400405-117	400405-142	04
WPDU/WSDU	55	23	10,5	9/11,2	-40 to +75	II3D IP67 T 200°C	IP67 steel/SS	- ⁽⁴⁾	- ⁽⁴⁾	04
NF/WSNF	55	23	10,5	-	(-60) ⁽⁷⁾ -40 to +25/40/60	II2G Ex d IIC T6/T5/T4, II2D Ex tD	IP67 alum./SS	400405-117	-	02
NF/WSNF	-	-	-	9/11,2	(-60) ⁽⁷⁾ -40 to +40/60/75	II2G Ex d IIC T6/T5/T4, II2D Ex tD	IP67 alum./SS	-	400405-142	02
EM/WSEM	55	23	10,5	9/11,2	-40 to +40	II2G Ex e mb II T3, II2D Ex tD	IP67 steel/SS	400909-117	400913-142	04
PV	55	23	10,5	9/11,2	-40 to +65	II2G Ex mb II T3(-)/T4(-), II2D Ex mD 21	IP67 moulded	- ⁽⁴⁾	- ⁽⁴⁾	05
EF/EV	55	23	10,5	9/11,2	-40 to +54/40	NEMA type 7 and 9	NEMA 4X	238614-058	238714-006	06
ZN	55	23	10,5	9/11,2	-20 to +50	II3GD EEx nA II T3	IP65 moulded	- ⁽⁴⁾	- ⁽⁴⁾	01
Low power (LP)										
SC	1,5	1,5	1,5	1,7/1,7	-40 to +60	EN 60730	IP65 moulded	400925-097	400925-042	07
WP/WS	1,5	1,5	1,5	1,7/1,7	-40 to +60	EN 60730	IP67 steel/SS	400926-097	400926-042	09
LPKF/WSLPKF ⁽⁸⁾	2,4	2,4	2,4	0,5/0,5 ⁽⁸⁾	-40 to +80/60	II2G Ex d IIB+H2 Gb T4/T6, II2D Ex tDb	IP67 alum./SS	- ⁽⁴⁾	- ⁽⁴⁾	13
NF/WSNF	-	-	1,9	- /1,9	(-60) ⁽⁷⁾ -40 to +75/80	II2G Ex d IIC T6/T5, II2D Ex tD	IP67 alum./SS	- ⁽⁴⁾ ⁽⁵⁾	- ⁽⁴⁾	08
EM/WSEM	1,5	1,5	1,5	1,7/1,7	-40 to +40/55	II2G Ex e mb II T6/T5, II2D Ex tD	IP67 steel/SS	- ⁽⁴⁾	- ⁽⁴⁾	09
PV	-	-	-	1,7/1,7	-40 to +65	II2G Ex mb II T6 / II2D Ex mD 21	IP67 moulded	-	- ⁽⁴⁾	10
EF/EV	-	-	-	1,7/1,7	-40 to +60	NEMA type 7 and 9	NEMA 4X	-	- ⁽⁴⁾	11
ISSC ⁽³⁾	-	-	-	0,4/0,4	-40 to +60	II1G Ex ia IIC T6, II2D Ex iaD 21	IP65 moulded	-	268976-001	12
LI ⁽³⁾	-	-	-	0,5/0,5	-40 to +60	II2G Ex ib IIC Gb T6, II2D Ex t IIC Db	IP67 alum.	-	- ⁽⁴⁾	14
WSLI ⁽³⁾	-	-	-	0,5/0,5	-40 to +60	II1G Ex ia IIC Ga T6, II2D Ex t IIC Db	IP67 SS	-	- ⁽⁴⁾	14
WPIS/WSIS ⁽³⁾	-	-	-	0,4/0,4	-40 to +60	II1G Ex ia IIC T6, II2D Ex iaD 21	IP67 steel	-	268900-001	09
ZN	-	-	-	1,7/1,7	-20 to +50	II3GD EEx nA II T3	IP65 moulded	-	- ⁽⁴⁾	07

prefix option	safety parameters				
	U _i = (DC) (V)	I _i (mA)	P _i (W)	L _i (H)	C _i (µF)
Low power (LP)					
ISSC	32	500	1,5	0	0
WPIS/WSIS	32	500	1,5	0	0
LI/WSLI	32	500	1,5	0	0

- ⁽¹⁾ Temperature range can be limited by sealings
- ⁽²⁾ Refer to the dimensional drawings on pages: 4 to 7
- ⁽³⁾ ISSC/WPIS/WSIS/LI/WSLI: Check the electrical characteristics in the corresponding catalogue pages
- ⁽⁴⁾ Multiple coil kits are available under ATEX/IECEx, contact us
- ⁽⁵⁾ (WS)NF: Low Power, 230 V AC does not exist. Maximum voltage in AC is 115 V
- ⁽⁶⁾ LI/WSLI: Low Power, 24 V DC only
- ⁽⁷⁾ The certified minimum temperature of this operator
- ⁽⁸⁾ LPKF/WSLPKF: 24 V DC, max. ambient temp. +80°C, contact us (48 V DC = 2,1 W)
- Not available

ELECTRICAL CONNECTIONS

prefix	connection
SC, SCDU, ZN, ISSC	Spade plug connector with cable gland EN175301-803A (ISO 4400) for cables with an outer diameter from 6 to 10 mm
WP, WS, EM, WSEM, WPDU, WSDU, WPIS, WSIS	M20 cable gland for cables with an outer diameter from 7 to 12 mm. With an internal and external facility for an earthing or bonding conductor
NF, WSNF, LPKF, WSLPKF	1/2" NPT threaded cable entry. Enclosures are supplied without cable gland
PV	Moulded-in cable, standard length 2 m
LI, WSLI	1/2 cable gland for cables with an outer diameter from 6 to 12 mm. With an internal and external facility for an earthing or bonding conductor
EF, EV	1/2" NPT conduits, standard length 35 cm

ADDITIONAL OPTIONS

- Valves configured for external pilot air supply, TPL 20547
- Other pipe threads are available on request
- Ex mb/mD (prefix "PV") solenoid can be supplied with various cable lengths
- Compliance with "UL", "CSA" and other local approvals available on request
- 1/2" NPT (prefix "T") and M20 x 1.5 (prefix "ET") conduits (aluminium or 316 SS) available for steel solenoid housing

INSTALLATION

- Multi language installation/maintenance instructions are included with each valve
- The solenoid valves can be mounted in any position without affecting operation
- Do not connect the pressure supply to the exhaust port 3. The "environmentally-protected" construction is not adapted for a "distributing" function or use in NO function. Contact us for functions available in specific versions
- IEC 61508 Functional Safety (suffix SL), allowable temperature range: -40°C to +60°C. For probability of failure, contact us
- It is necessary to connect pipes or fittings to the exhaust ports to protect the internal parts of the spool valve and its pneumatic operator if used outside or in harsh environments (dusts, liquids etc.)
- Threaded pipe connection identifier is: 8 = NPT (ANSI 1.20.3); G = G (ISO 228/1)
- Prefix "NF/WSNF" enclosure is provided with a 1/2" NPT threaded entry hole, M20 x 1,5 (prefix "ET") is optional. Both are supplied without cable gland

DIMENSIONS (mm), WEIGHT (kg)

All types

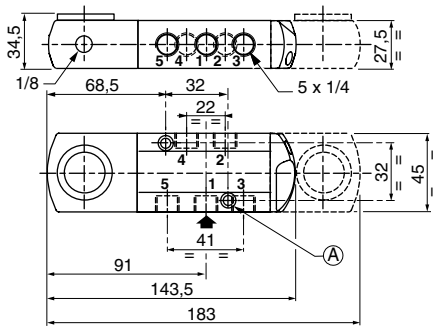

(A) 2 mounting holes 5.3 mm dia.;
Spotfacing: 9 mm dia., depth 5 mm



TYPE 01: Prefixes SC: IP65, ZN: II 3 G/D, IP65,
EEx nA II, SCDU: II 3 D, IP65, T100°C to 200°C
Basic power
Epoxy moulded
IEC 335 / ISO 4400

551A419 / 551A420



TYPE 02:
Ex d IIC
NF / WSNF
Aluminium; epoxy coated / AISI 316 SS
EN/IEC 60079-1 and EN/IEC 61241-1

551A419 / 551A420

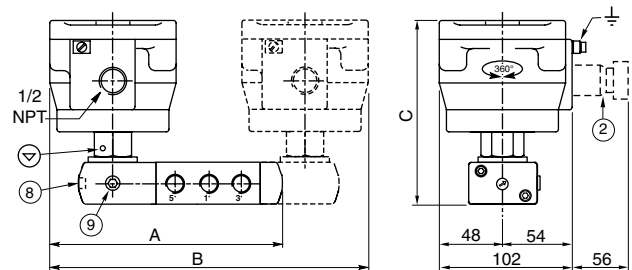
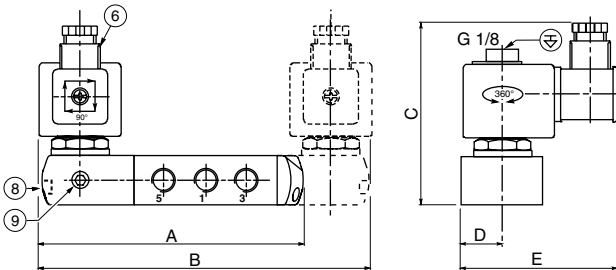

TYPE 04:
WP / WS
EM / WSEM
WPDU / WSDU
Steel; epoxy coated / AISI 316 SS
IEC 335 / EN 60079-7/18 and EN 61241-1

551A419 / 551A420

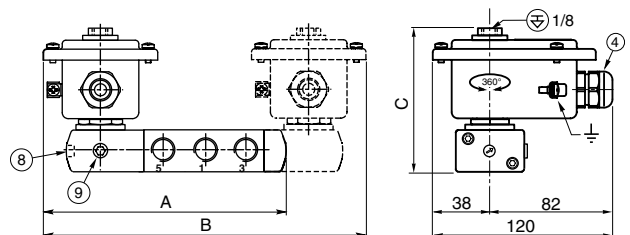

DIMENSIONS (mm), WEIGHT (kg) 



TYPE 05:
PV
Epoxy encapsulated
EN/IEC 60079-18 and EN/IEC 61241-18

551A419 / 551A420

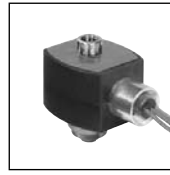
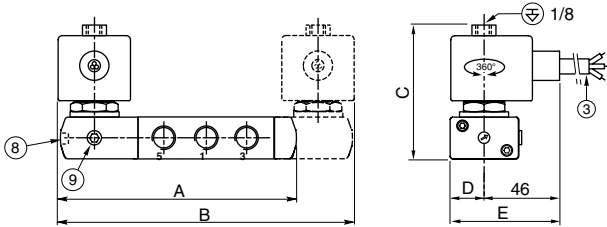

TYPE 06:
EF and EV: NEMA type 7 and 9
Epoxy encapsulated
ICS-6 ANSI
NOTE: applicable to solenoid only

551G419 / 551G420

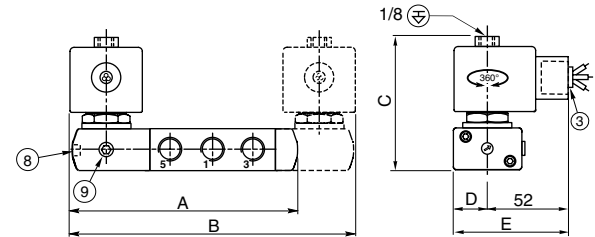

TYPE 07:
SC and ZN
Epoxy moulded
IEC 335 / ISO 4400
EN 50021

551A319 / 551A320

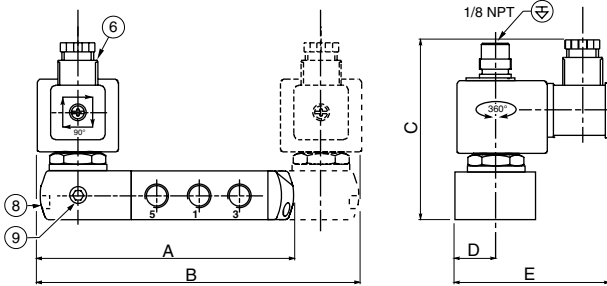

TYPE 08:
NF / WSNF
Aluminium; epoxy coated / AISI 316 SS
EN/IEC 60079-1 and EN/IEC 61241-1

551A319 / 551A320

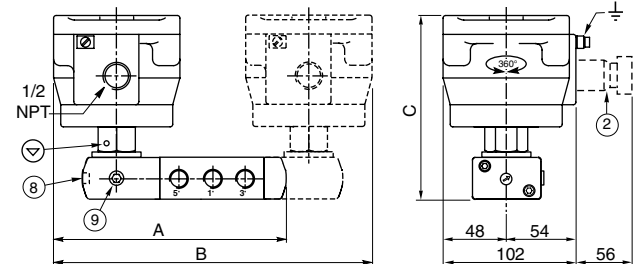

TYPE 09:
WP / WS
EM / WSEM
WPIS / WSIS
Steel; epoxy coated / AISI 316 SS
IEC 335/EN 60079-7/11/18/26 and EN 61241-1/1

551A319 / 551A320

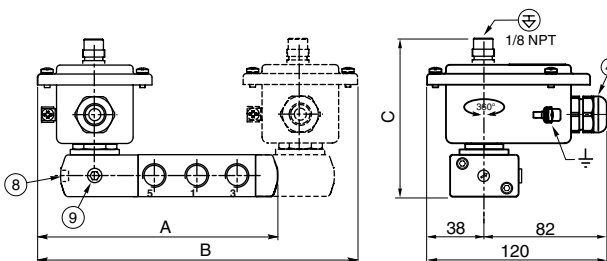

TYPE 10:
PV
Epoxy encapsulated
EN/IEC 60079-18 and EN/IEC 61241-18

551A319 / 551A320

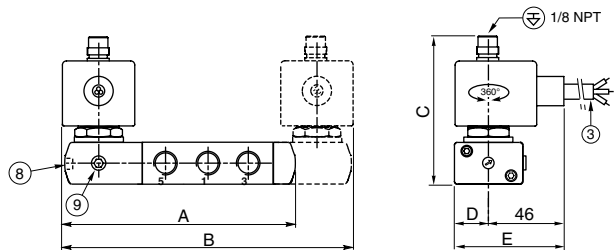

DIMENSIONS (mm), WEIGHT (kg)



TYPE 11: Prefixes EF/EV: ICS-6 ANSI / NEMA EF and EV: NEMA type 7 and 9
Epoxy encapsulated
ICS-6 ANSI
NOTE: applicable to solenoid only

551H319 / 551G320



TYPE 12:
ISSC
Polypropylene moulded
Epoxy moulded
IEC 335/EN 60079-11/26 and EN/IEC 61241-11

551A319 / 551A320

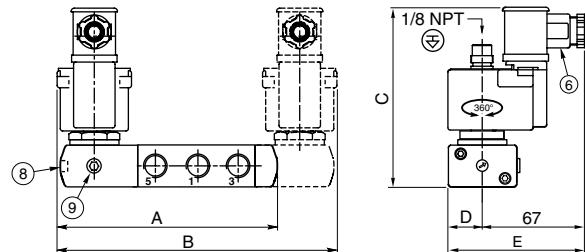
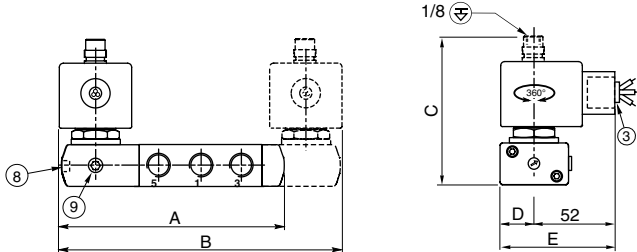

TYPE 13:
LPKF / WSLPKF
Aluminium, cataphoresis black painting / AISI 316L SS
EN/IEC 60079-1 and EN/IEC 61241-1

551A319 / 551A320



TYPE 14:
LI: II 2G Ex ia IIC Gb T6, II 2D Ex t IIIC IP67 Db
WSLI: II 1G Ex ia IIC Ga T6, II 2D Ex t IIIC IP67 Db
Aluminium, cataphoresis black painting, AISI 316L SS
IEC and EN: 60079-11, 61241-1

551A319 / 551A320

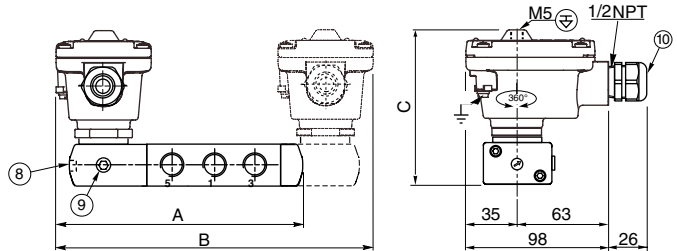
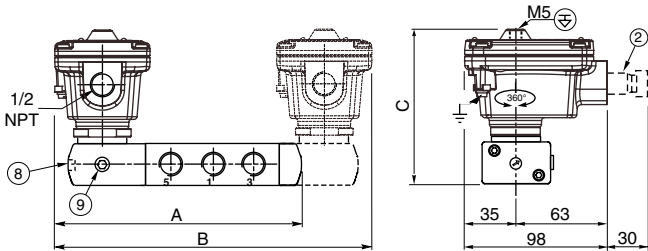

DIMENSIONS (mm), WEIGHT (kg)

type	prefix option	power level	A	B	C	D	E	weight ⁽¹⁾	
								monostable	bistable
01	SC / SCDU / ZN	basic power	144	182	102,7	22,5	86,5	1,52	2,28
02	NF	basic power	170	236	141,8	-	-	2,61	4,45
02	WSNF	basic power	170	236	141,8	-	-	3,91	5,75
04	WP/WPDU/WS/WSDU/EM/WSEM	basic power	160	216	103	-	-	1,70	2,43
05	PV	basic power	144	184	88	22,5	67,5	1,58	2,39
06	EF / EV	basic power	144,5	185	85,5	22,5	74,5	1,40	2,23
07	SC / ZN	low power	144,5	185	101,5	22,5	87,5	1,67	2,57
08	NF	low power	170	236	141,8	-	-	2,55	4,53
08	WSNF	low power	170	236	141,8	-	-	3,85	5,83
09	WP / WS / EM / WSEM / WPIS / WSIS	low power	160	216	102,2	-	-	1,75	2,72
10	PV	low power	144	184	100,5	22,5	67,5	1,73	2,69
11	EF / EV	low power	144,5	185	100,5	22,5	74,5	1,55	2,52
12	ISSC	low power	134	187	124,5	22,5	89,5	1,50	2,43
13	LPKF	low power	153	204	113	-	-	1,66	2,56
13	WSLPKF	low power	153	204	113	-	-	2,27	3,76
14	LI	low power	153	204	113	-	-	1,67	2,57
14	WSLI	low power	153	204	113	-	-	2,28	3,77

⁽¹⁾ Incl. coil(s) and connector(s)

- ② Ex d certified cable gland (on request)
- ③ Three-core cable, length 2 m
- ④ Cable gland for unarmoured cable with 7 to 12 mm dia. sheath
- ⑥ Connector rotatable by 90° increments (cable Ø 6 - 10 mm)
- ⑧ Push type or screw type manual operator, suffix MO
- ⑨ External pilot air supply, 1/8 pipe size
- ⑩ Cable gland for unarmoured cable with 6 to 12 mm dia. sheath
- ⊕ Connectable pilot exhaust port
- ⊖ Non-connectable pilot exhaust port

ACCESSORIES

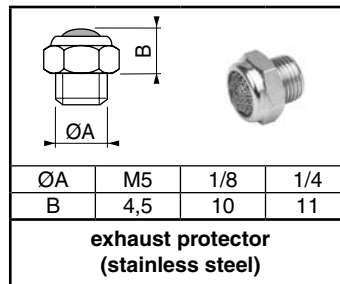
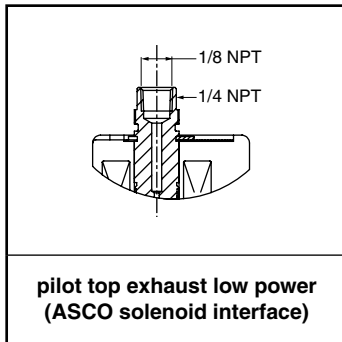
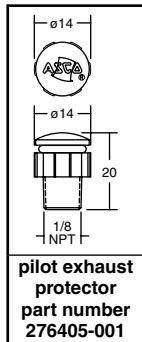

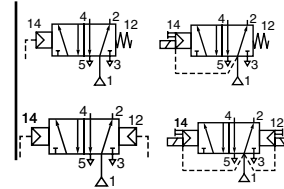

FEATURES

- The monostable spool valves have TÜV certified IEC 61508 Functional Safety data and can be used up to SIL 4
- All the exhaust ports of this spool valve are connectable, providing better environmental protection, particularly recommended for sensitive areas such as clean rooms, and applications in the pharmaceutical and food processing sectors
- The valve offers environmental protection against the ingress of liquids, dusts or any other foreign matter (environmentally-protected construction)
- The solenoid valves satisfy all relevant EC Directives

GENERAL

Differential pressure 2 - 10 bar [1 bar =100 kPa]
Flow (Qv at 6 bar) 860 l/min (ANR)

fluids (*)	temperature range (TS)	seal materials (*)
air, inert gas, filtered	- 40°C to + 60°C ⁽²⁾	VMQ (silicone) + PUR (polyurethane)

⁽²⁾ -40°C for air operated versions.

MATERIALS IN CONTACT WITH FLUID

(*) Ensure that the compatibility of the fluids in contact with the materials is verified

	Air operated	CNOMO solenoid (pilot) interface
Body, end covers	Brass, AISI 316L	Brass, AISI 316L
Spool valve internal parts	Brass, stainless steel, POM	Brass, stainless steel, POM
Seals	NBR	NBR
Pilot internal parts	-	Size 15 (E06.36.120N), 302 pilot (CFSC/CFVT/CFSCIS) and 630 piezotronic pilot (PISC/PISCIS)

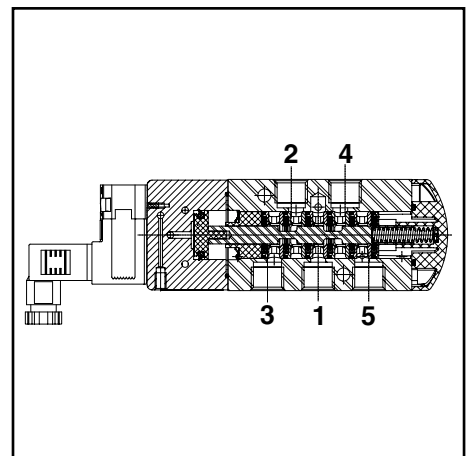

AIR OPERATED SPECIFICATIONS

pipe size	orifice size	flow coefficient kv		operating pressure differential (bar)			prefix optional	basic catalogue number
				min.	max. (PS)			
(*)	(mm)	(m³/h)	(l/min)		air (*)			
					~	=		
Pilot air operated - spring return (monostable)								
1/4	6	0,75	12,5	2	10	10	-	❖551A119 ⁽¹⁾
Pilot air operated and return (bistable)								
1/4	6	0,75	12,5	2	10	10	-	❖551A120

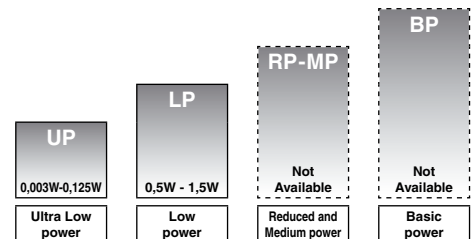

POWER LEVELS - cold electrical holding values (watt)

CNOMO SOLENOID (PILOT) INTERFACE SPECIFICATIONS

pipe size	orifice size	flow coefficient kv		operating pressure differential (bar)			power level	prefix optional solenoids					basic catalogue number
				min.	max. (PS)			ATEX / IECEx		IP65			
(*)	(mm)	(m³/h)	(l/min)		air (*)		~/=	CFSCIS	PISCIS	CFSC	CFVT	PISC	CNOMO size 15
					~	=							
Solenoid air pilot operated - spring return (monostable)													
1/4	6	0,75	12,5	2	10	10	LP	-	-	●	●	-	❖551C519 ⁽¹⁾
1/4	6	0,75	12,5	2	-	8	LP	○	-	-	-	-	❖551C519 ⁽¹⁾
1/4	6	0,75	12,5	2	8	8	UP	-	○	-	-	●	❖551C519 ⁽¹⁾
Solenoid air pilot operated and return (bistable)													
1/4	6	0,75	12,5	2	10	10	LP	-	-	●	●	-	❖551C520
1/4	6	0,75	12,5	2	-	8	LP	○	-	-	-	-	❖551C520
1/4	6	0,75	12,5	2	8	8	UP	-	○	-	-	●	❖551C520

❖ Select 8 for NPT ANSI 1.20.3 or select G for ISO G (228/1) ● Available feature ○ Available feature in DC only.

⁽¹⁾ Certified IEC 61508 Functional Safety data, use suffix "SL".

PREFIX TABLE

prefix							description	power level			
1	2	3	4	5	6	7		UP	LP	RP	BP
C	F	S	C				Solenoid + spade plug DIN 43650, 9,4 mm, industry standard B (EN 60730)	-	●	-	-
C	F	V	T				Solenoid with connection M12, LED + protection (EN 60730)	-	○	-	-
C	F	S	C	I	S		Intrinsically safe, 9,4 mm, pilot 302; ATEX (EN 60079 / 61241) *	-	○	-	-
P	I	S	C				Solenoid, spade plug DIN 43650, 9,4 mm, industry stand. B, ATEX (EN 60730)	●	-	-	-
P	I	S	C	I	S		Intrinsically safe, piezotronic 630 pilot, ATEX (EN 60079/61241) *	○	-	-	-

SUFFIX TABLE

suffix							description	power level			
1	2	3	4	5	6	7		UP	LP	RP	BP
	G	D					Non-electrical, 1 GD c, construction safety, gas/dust (EN 13463-5)	-	-	-	-
			M	S			Screw type manual operator ⁽¹⁾	-	○/●	-	-
			M	O			Push type manual operator	○/●	○/●	-	-
S	L						Certified IEC 61508 Functional Safety data ⁽¹⁾	○/●	○/●	-	-

OPTIONS & ACCESSORIES

series	pipe size	exhaust protector (stainless steel)
551	G 1/4	34600419 ⁽²⁾
	NPT 1/4	34600483 ⁽²⁾
	M5	34600484 ⁽²⁾

- Available feature
- Available feature in DC only
- Not available
- * ATEX solenoids are also approved according to EN 13463-1 (non electrical valves)
- ⁽¹⁾ Not to use with "SL" suffix
- ⁽²⁾ Provided with "SL" suffix

PRODUCT SELECTION GUIDE

STEP 1

Select the fluid temperature range and seal material from the general table on page 9. Select basic catalogue number, including pipe thread identification letter. Refer to the specifications tables on page 9.

Example: G551C519

STEP 2

Select prefix (combination). Select the appropriate operator from the tables on pages 9 and 10. Select for this operator in the electrical characteristics table on page 11: the power level (UP, LP), the type of electrical enclosure protection and the desired temperature class.

Warning: The ambient temperature range of your application may not exceed the temperature range of your operator.

Example : CFSC

STEP 3

Select suffix. Suffix **MO** mandatory for the pilot 302 (CFSCIS). Refer to the suffix table on page 10, respect the indicated power level.

Example : MO

STEP 4

Selection of TPL, on page 11, is mandatory for the 630 pilot (PISCIS), 12 HV DC (32 mW) and 24 HV DC (125 mW). Add "X" between the prefix "PISCIS" and the basic catalogue number.

STEP 5

Select voltage. Refer to standard voltages on page 11.

Example : 230V / 50Hz

STEP 6

Final catalogue / ordering number.

Example :
CFSC G551C519MO 230 V / 50 Hz

ORDERING EXAMPLES:

CFSC	G	551	C	519	230V / 50 Hz	
CFSC	G	551	C	519	SL	230V / 50 Hz
CFVT	8	551	C	520	MO	230V / 50 Hz
PISCIS	G	551	C	519	MO	6V / DC
PISCIS	G	551	C	519	SLMO	6V / DC
PISCIS X	G	551	C	520	MS	TPL20666 24HV / DC
					G 551 A 119	
					G 551 A 119	GD
					G 551 A 119	GDSL
					G 551 A 120	

prefix	_____	voltage	_____
pipe thread	_____	TPL	_____
basic number	_____	suffix	_____

EXPLANATION OF TEMPERATURE RANGES OF SOLENOID VALVES

Valve temperature range	The valve temperature range (TS) is determined by the selected seal material, the temperature range for proper operation of the valve and sometimes by the fluid (e.g. steam)
Operator ambient temperature range	The operator ambient temperature range is determined by the selected power level and the safety code
Total temperature range	The temperature range of the complete solenoid valve is determined by the limitations of both temperature ranges above

ELECTRICAL CHARACTERISTICS

Coil insulation class	F
Electrical safety	IEC 335
Standard voltages	DC (=) CFSC/ CFVT: 24V CFSCIS: 12V - 24V ; PISC: 24V à 70V ; PISCIS: 6V, 8V, 12V, 24V AC (~) CFSC: 24V - 115V - 230V/50Hz - Other voltages are available on request PISC: 24V to 70V

prefix option	power ratings				operator ambient temperature range (TS) (C°)	safety code	electrical enclosure protection (EN 60529)	replacement coil		type ⁽¹⁾
	inrush	holding		hot/cold				~	=	
	(VA)	(VA)	(W)	(W)				-	-	
Low power (LP)										
CFSC	1,4	1,2	1,1	1/1,12	-25 to +60	EN 60730	moulded IP65	-	-	01
CFSC	2,1 ⁽⁶⁾	1,6 ⁽⁶⁾	1,5 ⁽⁶⁾	-	-25 to +60	EN 60730	moulded IP65	-	-	01
CFVT ⁽⁵⁾	-	-	-	1,15/1,35	-25 to +60	EN 60730	moulded IP67/IP65	-	-	02
CFSCIS ⁽³⁾⁽⁴⁾	-	-	-	0,5	-10 to +40/60	II 1G Ex ia IIC T6/T4, II 1D Ex iaD 20	moulded IP65	-	-	04
Ultra low power (UP)										
PISC	-	-	-	0,007	-0 to +60	-	moulded IP65	-	-	06
PISCIS ^{(2)(3)6V}	-	-	-	0,003	-20 to +50	II 1G Ex ia IIC T6, II 1D Ex iaD 20	moulded IP65	-	-	06
PISCIS ^{(2)(3)8V}	-	-	-	0,022	-20 to +50	II 1G Ex ia IIC T6, II 1D Ex iaD 20	moulded IP65	-	-	06
PISCIS ^{(2)(3)12LV}	-	-	-	0,012	-20 to +50	II 1G Ex ia IIC T6, II 1D Ex iaD 20	moulded IP65	-	-	06
PISCIS ^{(2)(3)12HV}	-	-	-	0,032	-20 to +50	II 1G Ex ia IIC T6, II 1D Ex iaD 20	moulded IP65	-	-	06
PISCIS ^{(2)(3)12LV}	-	-	-	0,046	-20 to +50	II 1G Ex ia IIC T6, II 1D Ex iaD 20	moulded IP65	-	-	06
PISCIS ^{(2)(3)12HV}	-	-	-	0,125	-20 to +50	II 1G Ex ia IIC T6, II 1D Ex iaD 20	moulded IP65	-	-	06

- Not available

⁽¹⁾ Refer to the dimensional drawings on pages 12 and 13.

⁽²⁾ Piezotronic standards voltages:

Prefix PISCIS:	6 V DC / 3 mW	8 V DC / 22 mW	12 V DC / 12 mW	12 H V DC / 32 mW	24 V DC / 46 mW	24 H V DC / 125 mW
Turn ON voltage U _{ON}	6 .. 9 V	7,2 .. 12 V	10,8 .. 16 V	10,8 .. 16 V	21,6 .. 28 V	21,6 .. 28 V
Turn OFF voltage U _{OFF}	3 V	3,2 V	3,3 V	3,3 V	5 V	5 V
Peak current	6 mA	10 mA	6,8 mA	8,1 mA	10 mA	14 mA
Holding current	0,5 mA	2,8 mA	1 mA	2,7 mA	1,9 mA	5,2 mA
Cable + max. barrier resistances (R _s + R _v)	1200 Ω max.	300 Ω max.	1200 Ω max.	470 Ω max.	1200 Ω max.	470 Ω max.

prefix option	safety parameters				
	U _i	I _i	P _i	L _i	C _i
	= (DC) (V)	(mA)	(W)	(H)	(µF)
Low power (LP)					
CFSCIS	28	300	1,6	0	0
Ultra low power (UP)					
PISCIS	30	200	0,9	0	0

⁽³⁾ Intrinsically safe pilots: Check the electrical characteristics in the corresponding catalogue pages (CFSCIS: 302 pilot / PISCIS: 630 pilot).

⁽⁴⁾ CFSCIS (302 pilot):

12 V : I_(ON) min., with LED = 33 mA; U_(ON) min. = 11,9 V; U_(max) recommended = 23 V; U_(OFF) = 3,3 V; I_(OFF) = 10 mA
24 V : I_(ON) min., with LED = 25 mA; U_(ON) min. = 16,4 V; U_(max) recommended = 28 V; U_(OFF) = 5,7 V; I_(OFF) = 7 mA

⁽⁵⁾ Values for LED + protection.

⁽⁶⁾ AC: 230 V

- Not available

ELECTRICAL CONNECTIONS

prefix	connection
CFSC, CFSCIS, PISC, PISCIS	Spade plug connector with cable gland DIN 43650, 9,4 mm, industry standard B, for cables with an outer diameter from 4 to 6 mm
CFVT	M12 connection for M12 connector

ADDITIONAL OPTIONS

- TPL numbers: TPL **20665**: Piezotronic, PISCIS prefix, 12 HV (32 mW)
TPL **20666**: Piezotronic, PISCIS prefix, 24 HV (125 mW)
- TPL numbers: TPL **20674**: LED and protection, CFSC prefix - Add 0,15 W (DC) and 0,4 W/VA (AC)
Only available in 24 V AC/DC and 115 V AC
- Mounting on aluminium supply rail, 1/4 or 1/2
- Other pipe threads are available on request

INSTALLATION

- Installation/maintenance instructions are included with each valve
- The solenoid valves and air operated valves can be mounted in any position without affecting operation
- IEC 61508 Functional Safety (Suffix SL), allowable temperature range: -40°C to +60°C. Probability of failure on demand, contact us
- It is necessary to connect pipes or fittings to the exhaust ports to protect the internal parts of the spool valve and its pneumatic operator if used outside or in harsh environments (dusts, liquids etc.)
- Threaded pipe connection identifier is: 8 = NPT (ANSI 1.20.3); G = G (ISO 228/1)
- Valves with suffix "SL" are provided with a specific exhaust protector

DIMENSIONS (mm), WEIGHT (kg)

Type 01..06: CNOMO size 15 (E06.36.120N)

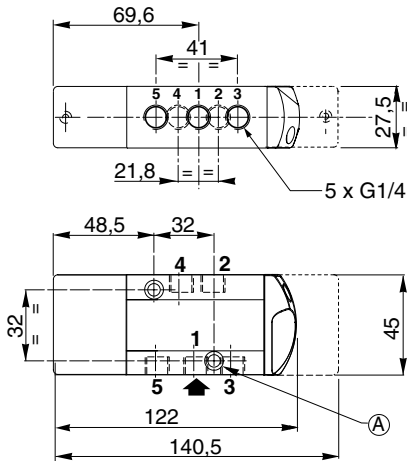

Type 07: Air operated

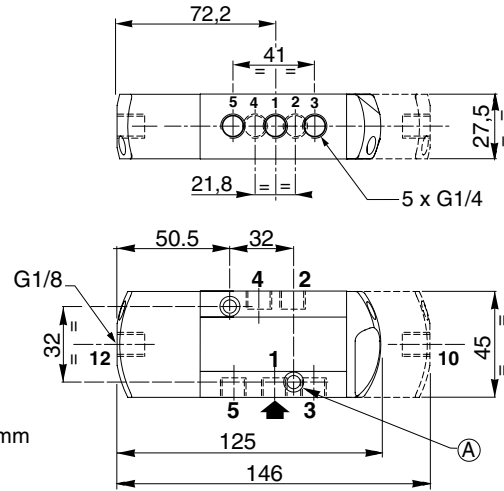

TYPE 01:
CFSC
302 pilot
Polyarylamide
IEC 335 / DIN 43650

551C519 / 551C520
551C519MS / 551C520MS / 551C519MO / 551C520MO



TYPE 02:
CFVT
302 pilot
Polyarylamide
IEC 335 / connection M12 + LED and protection

551C519 / 551C520
551C519MS / 551C520MS / 551C519MO / 551C520MO

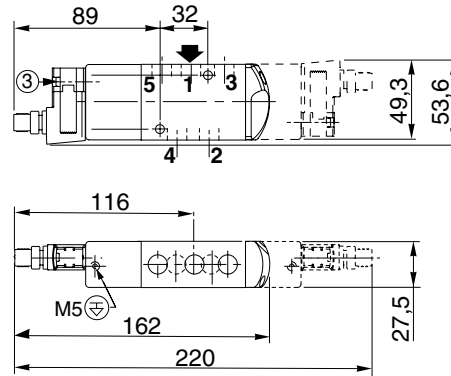
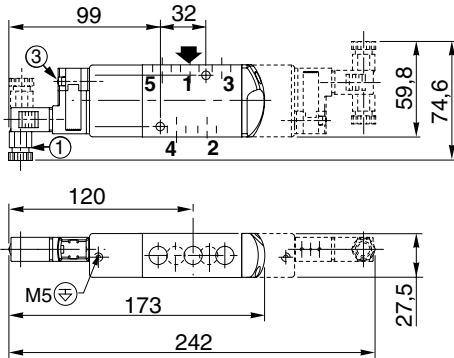

TYPE 04:
CFSCIS
302 pilot
Polyarylamide
IEC 335 / DIN 43650
EN/IEC 60079-11/26 and EN/IEC 61241-11

551C519MO / 551C520MO



TYPE 06:
PICS / PISCIS
Piezotronic pilot
Polyamide
IEC 335 / DIN 43650
EN 60079-11/26 and EN 61241-11

551C519MO / 551C520MO

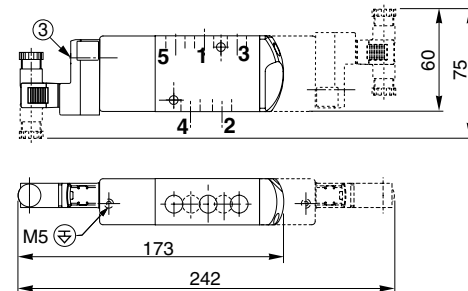
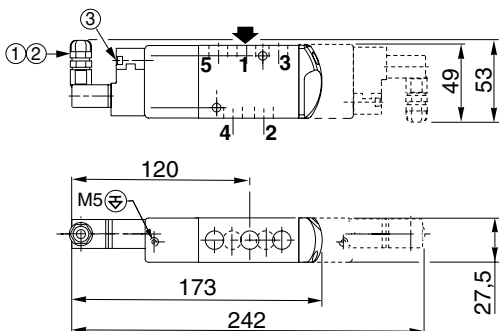

DIMENSIONS (mm), WEIGHT (kg)

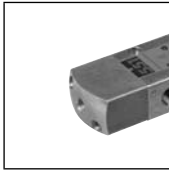

TYPE 07:

Air operated version
No prefix
Use "SL", "GD" or "GD SL" suffix
IP65 / II 1 GD c

551A119 / 551A120

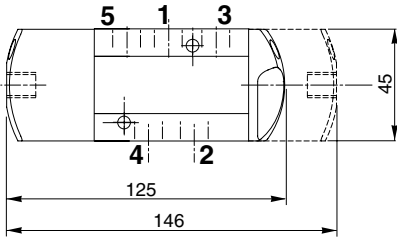
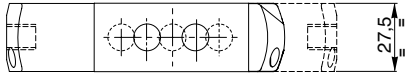

- ① Connector rotatable by 90° increments (cable 4 - 6 mm)
- ② Connector rotatable by 90° increments (cable 6 - 7 mm)
- ③ Manual operator location
- ⊕ Connectable pilot exhaust port

type	prefix option	power level	weight ⁽¹⁾	
			monostable	bistable
01	CFSC	low power	0,966	1,175
02	CFVT	low power	0,966	1,175
04	CFSCIS	low power	0,971	1,185
06	PISC / PISCIS	ultra low power	0,95	1,143
07	-	-	0,914	1,071

⁽¹⁾ Incl. connector(s), except CFVT.

ACCESSORIES

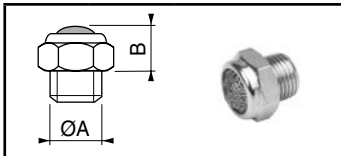

ØA	M5	-	1/4
B	4,3	-	11

**exhaust protector
(stainless steel)**

